



# DATA SHEET

## DMC

### FST Series Product Specification

Version 2.0

The information contained in this document has been carefully researched and is, to the best of our knowledge, accurate. However, we assume no liability for any product failures or damages, immediate or consequential, resulting from the use of the information provided herein. Our products are not intended for use in systems in which failures of product could result in personal injury. All trademarks mentioned herein are property of their respective owners. All specifications are subject to change without notice.

---

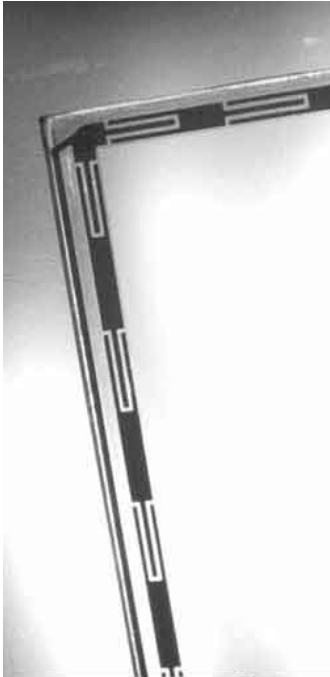

**DMC Co., Ltd.**

**5 Wire Analog Resistive Touchscreen  
FST Series Product Specifications**

**Table of Contents**

**1. Product Specifications ..... 3**

    1-1. Product Applicable ..... 3

    1-2. Structure ..... 3

    1-3. Environmental Specifications ..... 3

    1-4. Mechanical Characteristics ..... 3

    1-5. Electrical Characteristics ..... 3

    1-6. Appearance ..... 4

**2. Testing Regulation ..... 5**

    2-1. Testing Regulation ..... 5

    2-2. Environmental Specifications ..... 5

    2-3. Mechanical Characteristics ..... 5

    2-4. Electrical Characteristics ..... 5

    2-5. Appearance ..... 6

**3. Reliability Condition ..... 7**

    3-1. Temperature Condition ..... 7

**4. Recommended Connector ..... 7**

    4-1. Recommended Connector ..... 7

**5. Handling Notes ..... 8**

    5-1. Precautions ..... 8

    5-2. Handling Notes ..... 8

    5-3. Construction Notes ..... 8

    5-4. Electrical & Software Notice ..... 8

    5-5. Mounting Notes ..... 9

**6. Warranty ..... 10**

    6-1. Warranty Period ..... 10

    6-2. Warranty Target ..... 10

    6-3. Warranty Exceptions ..... 10

    6-4. Tools ..... 10

    6-5. Changes ..... 10

**7. Revision history ..... 11**

## 1. Product Specifications

### 1-1. Product Applicable

§ This specification is applied to the 5 wire analog resistive touchscreen: FST Series.

### 1-2. Structure

§ Dimensions, structure, and shape are referred on the drawing attached.

### 1-3. Environmental Specifications

Specification	Value
Operating Temperature	-20°C to 70°C (no condensation)
Operating Humidity	-20°C to 60°C Less than 90%RH (no condensation) Exceeding 60°C 133.8g/m <sup>3</sup> (no condensation)
Storage Temperature	-40°C to 80°C (no condensation)
Storage Humidity	-40°C to 60°C Less than 95%RH (no condensation) Exceeding 60°C 142.9g/m <sup>3</sup> (no condensation)
Chemical Resistance (top surface)	Toluene, Trichloroethylene, Athetone, Alcohol, Gasoline, Machine Oil, Ammonia, Glass Cleaner, Mayonnaise, Ketchup, Wine, Salad Oil, Vinegar, Lipstick, etc.

### 1-4. Mechanical Characteristics

Specification	Value
Activation Force	0.05N to 0.8N
Operating Life	Input (finger) 35,000,000 hits
	Character Input (pen) 100,000 characters
Light Transmittance	Over 80% (typical value at full wavelength)
Surface Hardness	Over 2H (by JIS pencil hardness)

### 1-5. Electrical Characteristics

Specification	Value
Maximum Voltage	DC6V
Maximum Current	Bottom Electrode 200mA
	Between the Top and Bottom 0.5mA
Linearity	Under ±2% (5% inside of active area after 9 points calibration.)
Terminal Resistance	Bottom Electrode Less than 200Ω
Insulation Resistance	Active Area Electrodes Over 20MΩ at 25V
Chattering	Less than 10msec at ON/OFF.

**1-6. Appearance**

§ Scratch, dust (W = width, L = length, D = average diameter = (longest + shortest) /2)

Item	Size (mm)	Length (mm)	Acceptable Numbers	Total
Scratch	$0.1 \geq W > 0.05$	$4 \geq L$	1pcs in $\phi 30\text{mm}$	Within 5pcs per product.
	$0.05 \geq W > 0.03$	$10 \geq L$	2pcs in $\phi 20\text{mm}$	
	$0.03 \geq W$	$20 \geq L$	Acceptable	
Dust (Linear)	$0.1 \geq W > 0.05$	$5 \geq L$	2pcs in $\phi 30\text{mm}$	
	$0.05 \geq W$	Acceptable	Acceptable	
Dust (Circular)	$0.4 \geq D > 0.3$ *1		1pcs in Viewing Area *1	
	$0.3 \geq D > 0.2$		2pcs in $\phi 30\text{mm}$	
	$0.2 \geq D$		Acceptable	

Applied only in the Active Area. Scratches or dusts in the outside of the Active Area are acceptable unless the electrical characteristics are affected.

\*1 Applied to the size of 14 inches or more.

§ Dirt

Acceptable if not noticeable on a black mat.

§ Tip, crack (t = glass thickness) (applicable only for the glass)

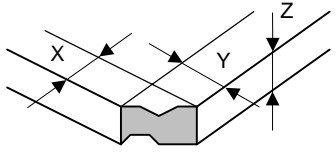
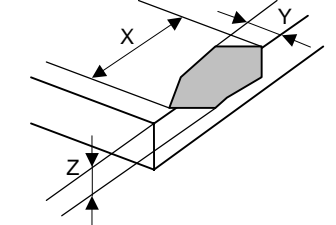
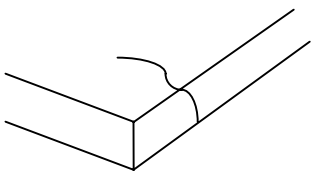
Item	Size (mm)	Acceptable Numbers	
Corner 	X	$\leq 3$	2pcs /panel
	Y	$\leq 3$	
	Z	$\leq t$	
Side 	X	$\leq 5$	2pcs /side
	Y	$\leq 3$	
	Z	$\leq t$	
Crack		0pcs (acceptable)	

**2. Testing Regulation**

**2-1. Testing Regulation**

§ If the regulation is not specified, the test is performed under the supplier's regulation.

§ Tests are performed under the room temperature unless specified. The room temperature is referred as follows:

Temperature: 20°C±5°C  
 Humidity: 65%±10%RH

**2-2. Environmental Specifications**

§ Chemical Resistance Test

Condition: Tested after leaving the chemical on the surface for 12 hours being wiped off by cloth.  
 Judgement: Must be no effect in appearance.

**2-3. Mechanical Characteristics**

§ Activation Force Test

Condition: Measured by depressing the point between the dots to the conduction by the testing rod.  
 Judgement: Must satisfy the specification.

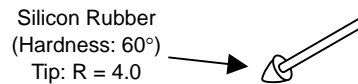

Figure 1: Testing rod 1

§ Operating Life Test (Finger)

Condition: Testing rod: Refer to Figure 1  
 Voltage: DC5V  
 Load: 300g  
 Cycle: 2 hits/sec

Judgement: Must satisfy the following:  
 Activation Force: Within ±50% of the specification.  
 Linearity: Must satisfy the specification.  
 Terminal Resistance: Must satisfy the specification.  
 Insulation Resistance: Must satisfy the specification.  
 Appearance: Must satisfy the specification.

§ Operating Life Test (Pen)

Condition: Testing rod: Refer to Figure 2  
 Voltage: DC5V  
 Load: 250g  
 Input size: 10 x 10 mm  
 Input character: A to Z/minute

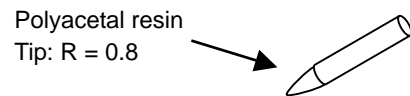

Figure 2. Testing rod 2

Judgement: Must satisfy the following:  
 Activation Force: Within ±50% of the specification.  
 Linearity: Must satisfy the specification.  
 Terminal Resistance: Must satisfy the specification.  
 Insulation Resistance: Must satisfy the specification.

**2-4. Electrical Characteristics**

## § Terminal Resistance Test

Condition: Top and bottom electrodes are measured at the terminal.

Judgement: Must satisfy the specification.

## § Insulation Resistance Test

Neighboring Terminals: Measured by applying the reference voltage to the terminals

Active Area Electrodes: Measured by applying the reference voltage to the top and bottom electrodes.

Judgement: Must satisfy the specification.

**2-5. Appearance**

## § Appearance Test

Condition: Tested by an examiner with over 1.0 eyesight at 30cm away from the product under the transmittable light at over 60° the surface of the product.

Judgement: Must satisfy the specification.

### 3. Reliability Condition

#### 3-1. Temperature Condition

##### § Temperature Condition Test

Following test are performed in the condition with no dew condensation:

Cold Test: Tested after leaving the parts in  $-30^{\circ}\text{C}\pm 3^{\circ}\text{C}$  for 240 hours and in the room temperature for 2 hours.

Heat Test: Tested after leaving the parts in  $80^{\circ}\text{C}\pm 3^{\circ}\text{C}$  for 240 hours and in the room temperature for 2 hours.

Humidity Test: Tested after leaving the parts in the temperature  $60^{\circ}\text{C}\pm 3^{\circ}\text{C}$ , humidity 90 to 95% for 240 hours and in the room temperature for 2 hours.

Cycle Test: Tested after 5 cycles of leaving the parts in the temperature  $-30^{\circ}\text{C}\pm 3^{\circ}\text{C}$  for 1 hour and in the room temperature for 0.5 hours, then leaving the parts in the temperature  $70^{\circ}\text{C}\pm 3^{\circ}\text{C}$  for 1 hour and in the room temperature for 0.5 hours.

Judgement: Must satisfy the following:

Activation Force: Within  $\pm 50\%$  of the specification.

Linearity: Must satisfy the specification.

Terminal Resistance: Must satisfy the specification.

Insulation Resistance: Must satisfy the specification.

Appearance: Must satisfy the specification.

### 4. Recommended Connector

#### 4-1. Recommended Connector

Part No.	Manufacturer	Pitch	Remarks
RE-H052SD-1110	J.S.T. Mfg Co., Ltd	2.54mm	equivalent

## **5. Handling Notes**

### **5-1. Precautions**

§ This product is intended for use in standard applications (computers, office automation, and other office equipment, industrial, communications, and measurement equipment, personal and household devices, etc.) Please avoid using this product for special applications where failure or abnormal operation may directly affect human lives, or cause physical injury or property damage, or where extremely high levels of reliability are required (such as aerospace systems, vehicle operating control, atomic energy controls, medical devices for life support, etc.).

### **5-2. Handling Notes**

§ Do not depress or scratch the product with any object with a sharp edge or end.

§ Do not forcibly bend or fold the product.

§ When the product is stored, make sure it is packed in a packing box and stored in a storage temperature range, eliminating any outside load.

§ Do not use or store the product under a condition where the product will be exposed to water, organic solution or acid.

§ Do not use the product under the direct sunlight.

§ Do not disassemble the product.

§ When you handle the product, Hold the product by its body. Do not hold by the tail.

§ Clean the product with a soft cloth or a soft cloth with neutral detergent or alcohol. When contaminated by chemicals, wipe them off immediately with caution not to cause injury to human body.

§ The edge of the glass is not rounded and may cause injury.

### **5-3. Construction Notes**

§ The environmental specifications, mechanical characteristics, and electrical characteristics are only applied to the Active Area.

§ Do not use the touchscreen when the condensation occurs. The condensation inside of the touchscreen is a natural phenomenon and should disappear after the touchscreen is warmed up.

### **5-4. Electrical & Software Notice**

The best performance can be obtained when used with the original 5 wire analog resistive touchscreen controller, "TSC-20" Series. If the touchscreen controller or controller software is to be developed by the customer, please note the following:

§ There is a contact resistance between the top and bottom electrodes and it changes by the pressure of a finger or a pen. The data must be read after the contact resistance becomes stabilized.

§ The terminal resistance of the 5 wire analog resistive touchscreen varies by the individual, time, and environment. The controller software must have the calibration function to adjust the input position and the display position.

§ The 5 wire analog resistive touchscreen outputs 2 point input as 1 point in between the 2 points. The controller software must not be designed to have the 2 point input function.

§ For drawing applications, the line may be intermittent when the pen comes on the dot spacers. A software compensation is needed.

**5-5. Mounting Notes**

§ Gap between the Bezel and Touchscreen

A gap of approximately 0.5mm is needed between the bezel and the top electrode. It may cause unexpected input if the gap is too narrow.

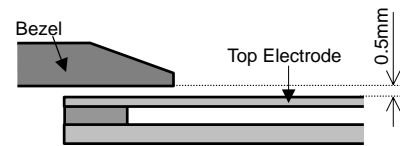

§ Cushion

If a cushion is used between the bezel and the top electrode, the cushion must be free enough to absorb the expansion and contraction difference between the bezel and the top electrode. If the cushion is squashed too hard, the expansion and the contraction difference may cause the distortion to the top electrode.

The cushion must be positioned within the insulation area.

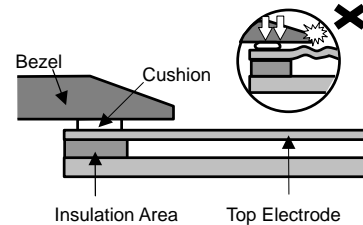

§ Tolerance

There is a tolerance of 0.2 to 0.3mm for the dimensions of the touchscreen and the tail. A gap must be made to absorb the tolerance in the case and the connector.

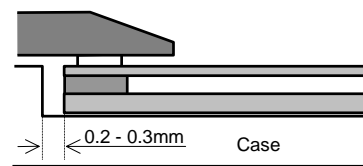

§ Tail

The tail must not be forcibly stressed or bent too hard to avoid the conduction in the insulated area and wire breaking.

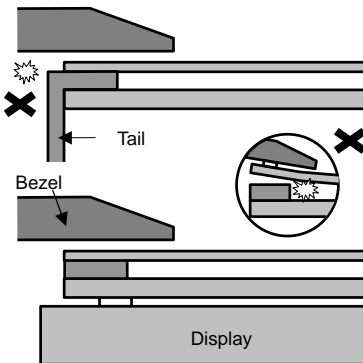

§ Mounting

Touchscreen must be held from the bottom such as the structure gluing the touchscreen onto the display. If the touchscreen is glued to the bezel, the adhesion between the top and bottom electrode is stressed and may come off.

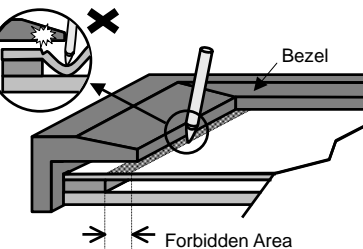

§ Forbidden Area

The area within 2mm from the insulation area is structurally weak for the pressure, especially for pen use. The film may be forcibly bent and may cause deflection. This area must be protected by the bezel and input must be avoided.

§ Air Vent

Most of the touchscreens have the air vent to equalize the inside air pressure to the outside one. The air vent must be open and liquid contact must be avoided as the liquid may be absorbed if the liquid is accumulated near the air vent. The top electrode must not be swelled by the air pressure from inside of the case.

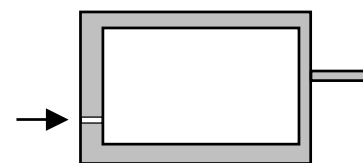

## **6. Warranty**

### **6-1. Warranty Period**

- § The warranty period is limited to 3 years from the date of shipping. The warranty for the initial deflection such as appearance deflection is limited to 1 month.
- § Any defected parts under proper use will be examined by the supplier and replaced by the new parts if the deflection is considered to be caused by the supplier.
- § The replacement is subject to be included in the next lot.

### **6-2. Warranty Target**

- § The warranty only covers the product itself and does not cover any damage to others caused by using this product. Onsite repair or replacement is not supported.
- § We will do our best for delivery problem and product deflections, but the warranty for the production line is not covered.
- § Resistive touchscreens are structurally not repairable. All deflections are subject to replacement.

### **6-3. Warranty Exceptions**

Following conditions are not covered with the warranty and subject to charge.

- § Any malfunctions and damages during transportation and transfer by the user.
- § Any malfunctions and damages caused by a natural disaster or a fire.
- § Any malfunctions and damages caused by static electricity
- § Any malfunctions and damages caused by the failure of the associated equipment.
- § If the product is remodeled, disassembled or repaired by the user.
- § If the product is glued onto the equipment and uninstalled.
- § Any malfunctions and damages caused by an improper usage and handling against the specifications and notes.

### **6-4. Tools**

- § To maintain the quality, the printing screens and the die-cut plates are generally limited to use up to 1 year. Reorders after 1 year from the initial order or from the last renewal are subject to the tooling charge for replacing the printing screens and the die-cut plates. Reorders for the discontinued standard parts are also subject to tooling charge.
- § All the tools, such as CAD data (except for the drawing for approval), block copies (films), printing screens, and die-cut plates are not to be provided for administrative purpose.

### **6-5. Changes**

- § Because of the manufacturing process, changing the dimensions, circuit pattern, and the tail position requires replacing most of the tools and is subject to high tooling charge. Please be careful when ordering and approving the drawing.
- § Circuit pattern and the materials that does not affect the environmental, electrical, and mechanical characteristics such as film, glass, ink and glue are subject to change for the supplier's reason or for improvement within the specifications.
- § Standard products are subject to change for improvement without notice.

## 7. Revision history

Rev1.0 (May 11, 2005)

Initial release

Rev1.1 (July 13, 2005)

4-1.Recommended Connector is changed RE-H052SD-1130 to RE-H052SD-1110.

6-1.Warranty Period is changed 5 years to 3 years.

Rev2.0 (October 13, 2006)

The specification item name was changed.

1-3."Storing Temperature" to "Storage Temperature"

1-3."Storing Humidity" to "Storage Humidity"

1-4."Operating Load" to "Activation Force"

1-4."Light Transmissivity" to "Light Transmittance"

1-4."Top Surface Hardness" to "Surface Hardness"

2-3."Operating Load Test" to "Activation Force Test"

2-3."Operating Load" to "Activation Force"

3-1."Operationg Load" to "Activation Force"

1-4.Activation Force is changed "0.5N±0.3" to "0.05N to 0.8N".

1-5.Linearity: Added "5% inside of active area after 9 points calibration."

1-5.Insulation Resistance is changed 100MΩ to 20MΩ.

1-6.The appearance inspection standard was improved.

1-6.Tip, crack: Deleted "Applied only in the Active Area. Scratches or dusts in the outside of the Active Area are acceptable unless the electrical characteristics are affected."

2-4.Added "Operating Life Test (Pen)".

FST Series Product Specifications  
Rev. 2.0, October 13, 2006  
© 2005 - 2006 DMC Co., Ltd.

This document can be freely distributed, but any alternation to this document is prohibited.

**DMC Co., Ltd.**

<http://www.dmccoltd.com>

9<sup>th</sup> floor, Kanda Sento Building, 1-2-4 Yushima, Bunkyo-Ku, Tokyo 113-0034, Japan

Phone: +81-3-5209-7131 (Japanese), 7135 (English) Fax: +81-3-5209-7130



DATA DISPLAY GROUP

Our company network supports you worldwide with offices in Germany, Turkey, Great Britain and the USA. For more information please contact:



DISTEC GmbH

**Distec GmbH**

Augsburger Str. 2

82110 Germering

Germany

Phone: +49 (0)89 / 89 43 63-0

Fax: +49 (0)89 / 89 43 63-131

E-Mail: info@distec.de

Internet: www.distec.de



DATA DISPLAY TEKNOLOJİ

**Data Display Teknoloji Elektronik San Ve Dış Tic A.Ş.**

Kustepe Leylak Sok.

Nursanlar Is Merkezi

Kat. 6 No: 21

Sisli / Istanbul

Turkey

Phone: +90 (0)212 / 356 04 20

Fax: +90 (0)212 / 356 04 25

E-Mail: info@datadisplay.com.tr

Internet: www.datadisplay.com.tr



DISPLAY TECHNOLOGY

**Display Technology Ltd.**

A2 Spectrum Business Centre

Anthony's Way, Medway City Estate

Rochester, Kent, ME2 4NP

United Kingdom

Phone: + 44 (0)1634 / 29 55 55

Fax: + 44 (0)1634 / 29 55 43

E-Mail: info@displaytechnology.co.uk

Internet: www.displaytechnology.co.uk



**Apollo  
Display  
Technologies**

A Data Display Company

**Apollo Display Technologies, Corp.**

85 Remington Blvd.

Ronkonkoma, NY 11779

United States of America

Phone: +1 631 / 580-43 60

Fax: +1 631 / 580-43 70

E-Mail: info@apollodisplays.com

Internet: www.apollodisplays.com